

# CREALITY

## CR-10S Pro V2 3D Printer User Manual

This User Manual is for standard CR-10S Pro V2.  
Please plug the power cord into a three-hole power jack.  
Detailed instructions for use are available in the TF card.

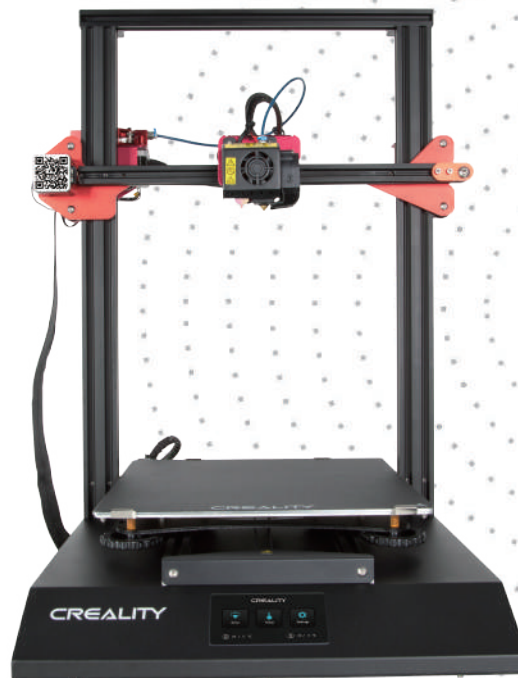

V.2.2

# Notes

1. Do not use the printer any way other than described herein in order to avoid personal injury or property damage.
2. Do not place the printer near any heat source or flammable or explosive objects. We suggest placing it in a well-ventilated, low-dust environment.
3. Do not expose the printer to violent vibration or any unstable environment, as this may cause poor print quality.
4. Before using experimental or exotic filaments, we suggest using standard filaments such as PLA to calibrate and test the machine.
5. Do not use any other power cable except the one supplied. Always use a grounded three-prong power outlet.
6. Do not touch the nozzle or printing surface during operation as they may be hot. Keep hands away from machine while in use to avoid burns or personal injury.
7. Do not wear gloves or loose clothing when operating the printer. Such cloths may become tangled in the printers moving parts leading to burns, possible bodily injury, or printer damage.
8. When cleaning debris from the printer hotend, always use the provided tools. Do not touch the nozzle directly when heated. This can cause personal injury.
9. Clean the printer frequently. Always turn the power off when cleaning, and wipe with a dry cloth to remove dust, adhered printing plastics or any other material off the frame, guide rails, or wheels. Use glass cleaner or isopropyl alcohol to clean the print surface before every print for consistent results.
10. Children under 10 years of age should not use the printer without supervision.
11. This machine is equipped with a security protection mechanism. Do not manually move the nozzle and printing platform mechanism manually while booting up, otherwise the device will automatically power off for safety!

# CONTENTS

Dear Consumers,

Thank you for choosing our products. For the best experience, please read the instructions before operating the Printer. Our 3D team will always be ready to give you the best service. Please contact us via the phone number or e-mail address provided at the end when you encounter any problem with the Printer.

For a better experience in using our product, you may learn how to use the Printer in the following ways:

1. View the accompanied instructions and videos in the TF card.
2. Visit our official website [www.creality3d.cn](http://www.creality3d.cn) You will find relevant software/hardware information, contact details and operation and maintenance instructions on the website.

Introduction.....	1
General List.....	2
Device Installation.....	3
Cable Connection.....	4
Screen Information.....	5
Loading Filament.....	6
Bed Leveling .....	7
Software Installation.....	9
First Printing.....	10
Circuit Wiring.....	11

## 1.Introduction

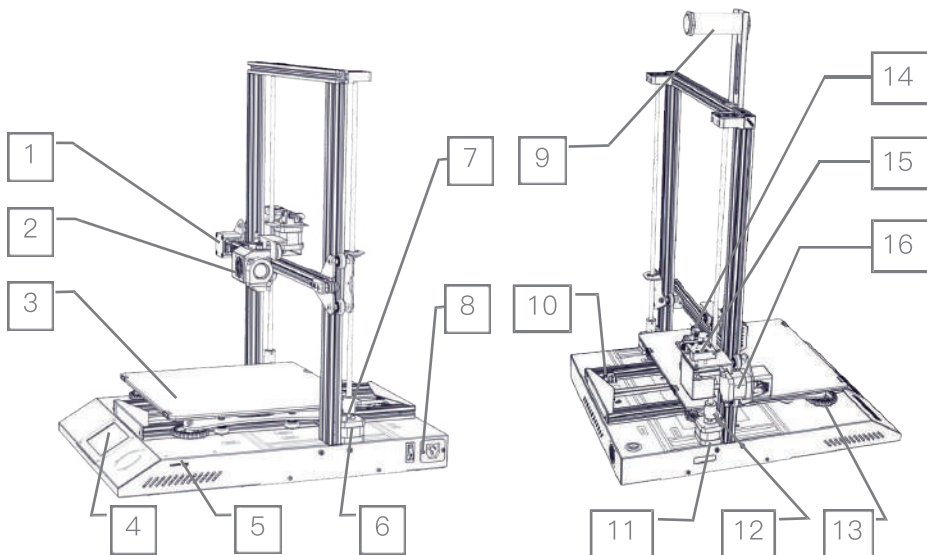

- |                       |                          |                         |
|-----------------------|--------------------------|-------------------------|
| 1. X Limit Switch     | 6. Z-axis Motor (Z2)     | 11. Z-axis Motor (Z1)   |
| 2. Nozzle Kit         | 7. Coupling (Z2)         | 12. Coupling (Z1)       |
| 3. Hot Bed            | 8. Power Switch & Socket | 13. XL Bed-leveling Nut |
| 4. Touch Screen       | 9. Filament Holder       | 14. Extruder (E) Motor  |
| 5. TF slot & USB Port | 10. Y Limit Switch       | 15. Filament Detector   |
|                       |                          | 16. X-axis Motor        |

Parameters	
Model	CR-10S Pro V2
Printing Size	300*300*400mm
Molding Tech.	FDM
Nozzle Number	1
Slice Thickness	0.1mm-0.4mm
Nozzle Diameter	Standard 0.4mm
Precision	±0.1mm
Filament	φ1.75mm PLA
File Format	STL/OBJ/AMF
Working Mode	Online or TF Card Offline
Slice Software	Cura/Repetier-Host/Simplify3D
Power Supply	Input:AC 100-240V 50/60Hz Output:DC 24V
Total Power	480W
Bed Temp.	≤100°C
Nozzle Temp.	≤250°C
Resume Print	Yes
Filament Detector	Yes
Dual Z-Axis	Yes
Auto leveling	Yes
Language Selection	EN/CN
Operating System	Windows XP/Vista/7/8/10 MAC/Linux
Printing Speed	≤180mm/s, Normal 30-60mm/s

## 2.General List

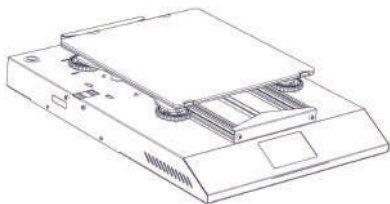

Base Frame

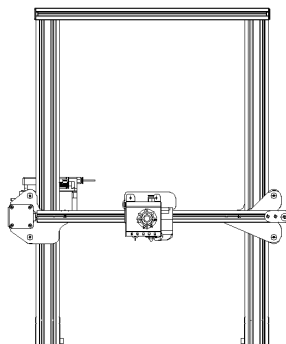

Gantry Frame



Tool Box



Filament(200g)

### ◆ Tool List

No.	Image	Name	Qty
1		Wrench & Screw driver	1set
2		TF Card & Reader	1set
3		Spade	1
4		Pliers	1
5		0.4mm Nozzle Cleaner	1

No.	Image	Name	Qty
6		Filament Holder Bracket	1
7		Filament Holder Tube with Nuts	1
8		Power Cable	1
9		USB Cable	1
10		PTFE Tube	1

No.	Image	Name	Qty
11		X-axis Spacer	1
12		Feeler	1
13		Spare Parts	1set
14		M5X25 black Hex-Bolt and Lock Washer	4set
15		M4X8 Screw and M4 T-nut	2set

## 3.Device Installtion

### ◆ Gantry Frame Installation

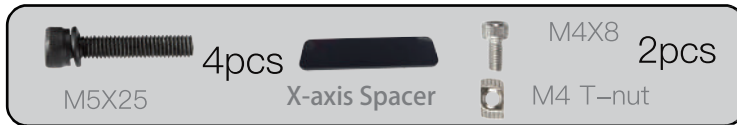
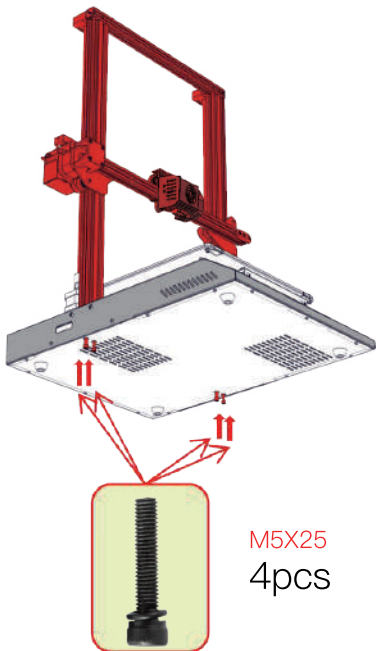

### ◆ Filament Holder Installation



### ◆ X axis adjustment

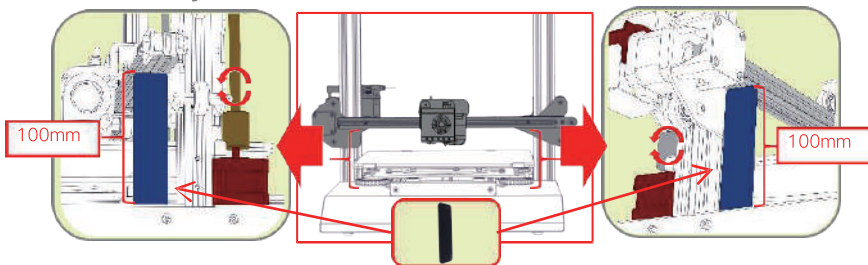

## 4.Cable Connection

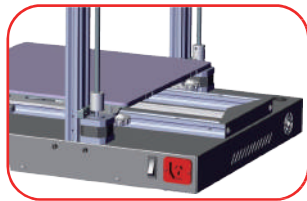
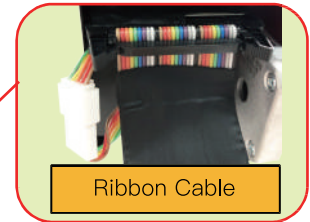
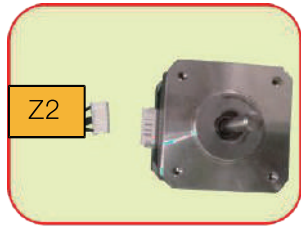

\*Plug the power cord into a three-hole power jack.

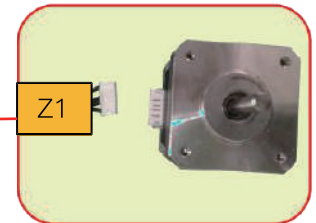
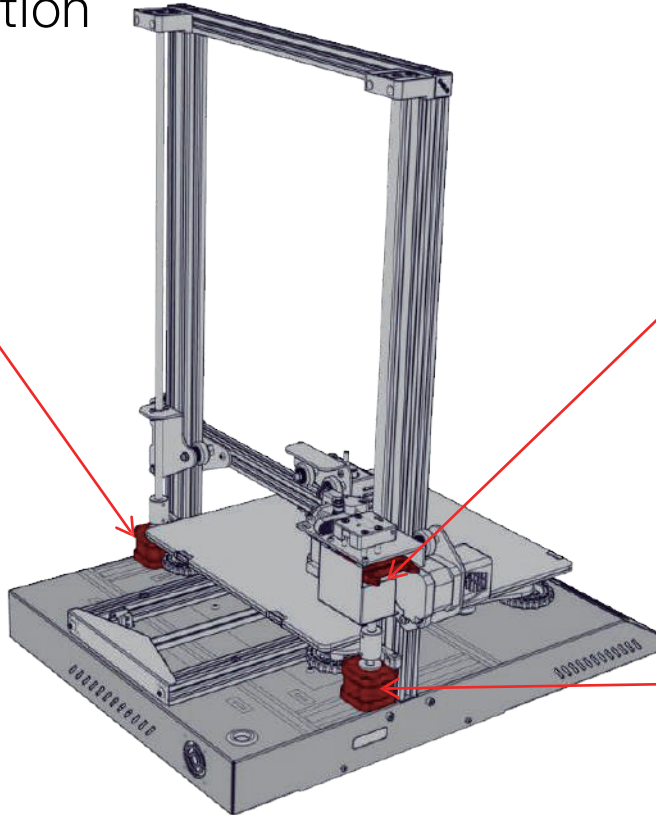

## 5.Screen Information

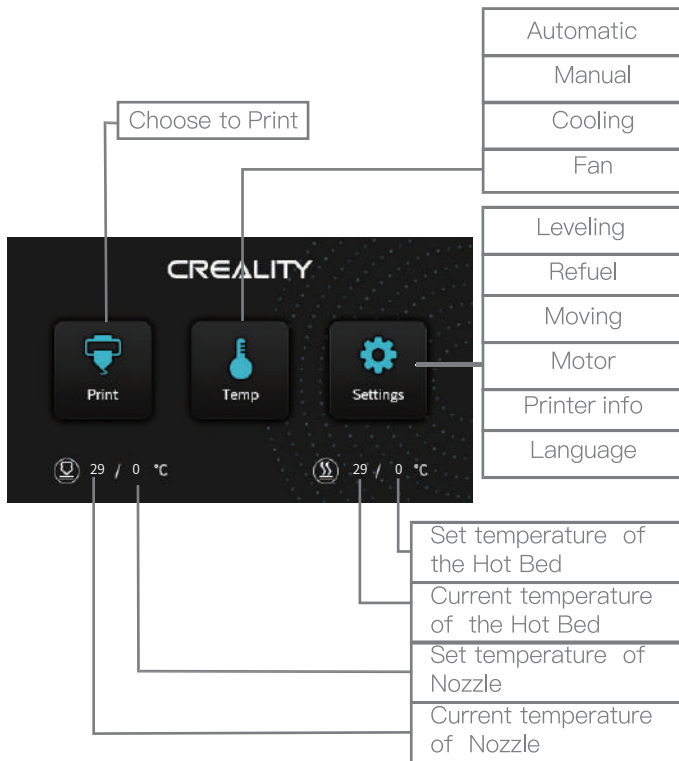

Screen Information					
Main Menu	Sub Menu	Explanation			
TF card	Selected file	Stop			
		Pause/Continue			
		Adjust	Print speed		
			Nozzle temp.		
			Hot-bed temp		
			Z offset		
fan					
Temp	Automatic	PLA\ABS (195*\240°)			
	Manual	Nozzle preheat			
	Manual	Hot-bed preheat			
	Cooling	Cool down? Yes\No			
Setting	Leveling	Turn on\Shut down			
		Z-axis: Z home, +0.1mm,-0.1mm			
		AUX leveling	Please click numbers to assist leveling (①-⑤)		
		AUTO leveling	Auto leveling, please wait...		
	Check level (Measurement parameters)				
	Refuel	Withdraw			
		Feed			
	Moving	X-axis	Y-axis	Z-axis	Z home
	Motor off	yes\no			
	Language	English\Chinese			
Printer info	Machine type, Firmware version, Printing size, website				



## 6.Loading Filament

### ◆ Preheat

Method 1、

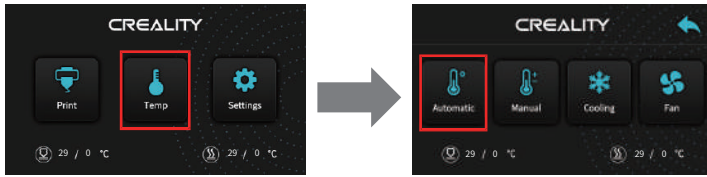

Method 2、

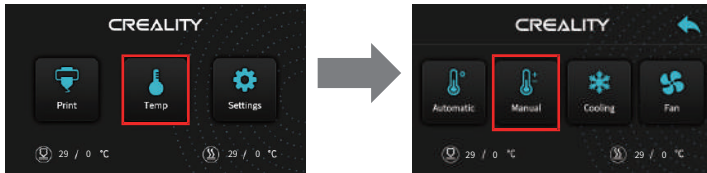

### ◆ Feeding

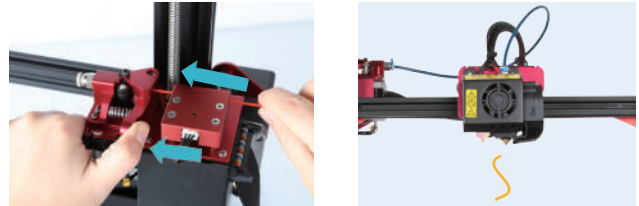

Press and hold the extruder lever and insert the 1.75mm filament through the filament detector and through the extruder motor. Continue feeding until you see filament extrude from the nozzle.

### Replacing Filament During Printing:

- 1、 Cutting the previous filament near the extruder and slowly feed new filament through the filament sensor and extruder, until the new filament is fed into the PTFE tube.  
(Or)
- 2、 Preheat the nozzle and withdraw the used filament. Feed the new filament as pictures above.

## 7. Bed Leveling



1. Slightly tighten the four leveling nuts at the bottom of the platform before initial leveling.
2. Select "Settings" → "Level mode", click on the number ②.

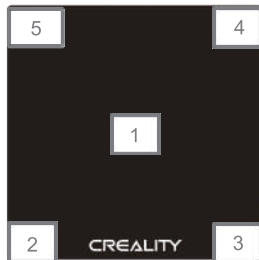
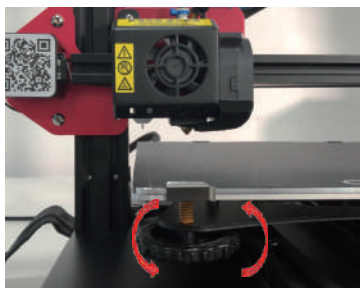

3. Adjust the platform height by turning the knob underneath. Use a piece of A4 paper (standard printer paper) to assist with the adjustment, making sure that the nozzle lightly presses on the paper.
4. Complete the adjustment on all 4 corners.
5. Click the number ① to test the platform height in the middle.
6. Repeat above steps one or two times if necessary.

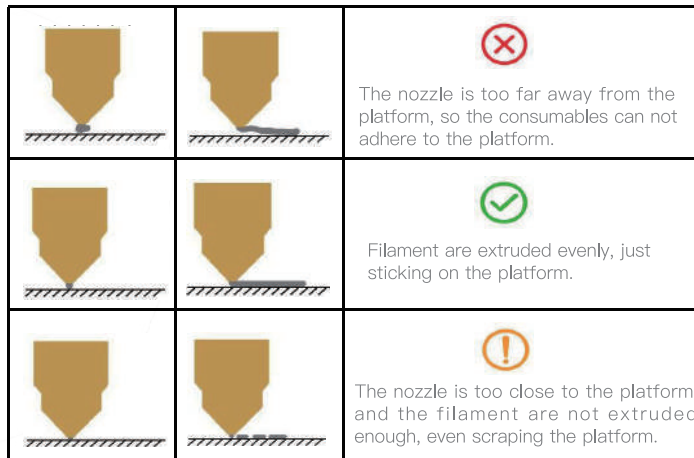

## ◆ Automatic leveling

If you need to do automatic leveling ,you can change it in the following interface:

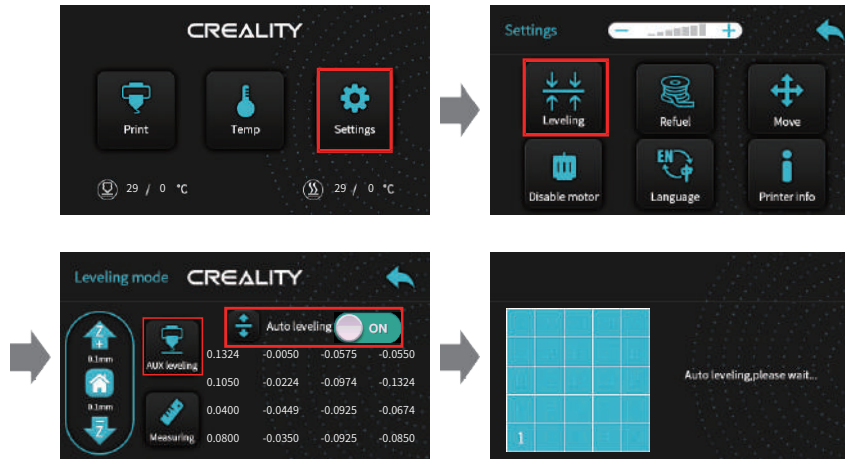

## 8. Software Installation



Creality  
Slicer\_1.2.3

1. Double click to install the software.



Creality Slicer

2. Double click to open the software.

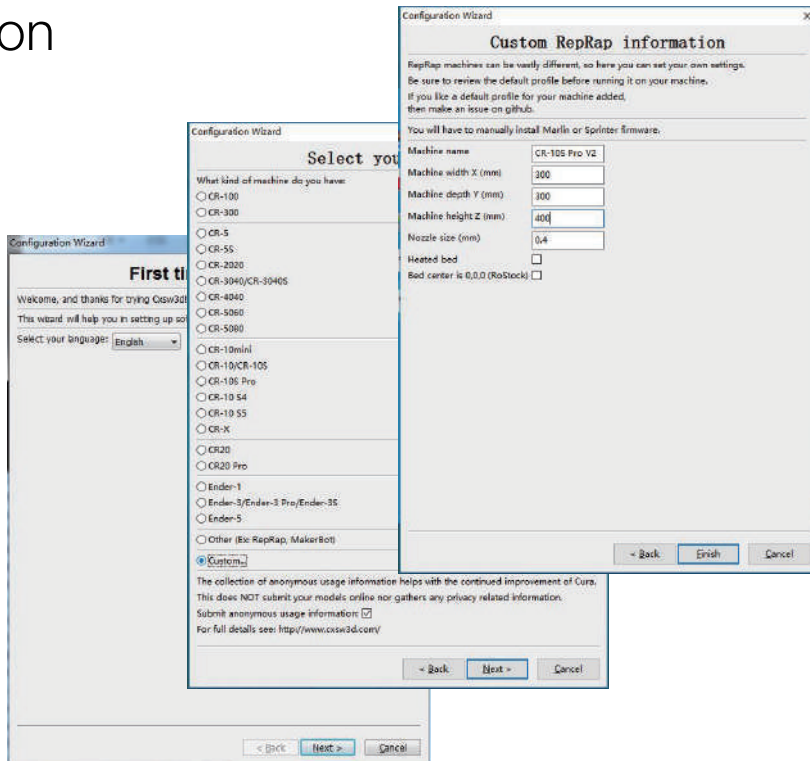

3. Select language→Next→Select your machine→Next→Finish.

## 9.First Printing

### 1.Slicing

Insert TF card into computer with Reader.

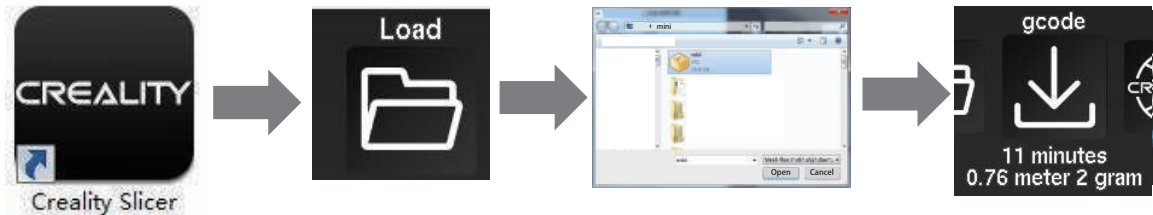

Open the software→Load→Select the file→Wait for slicing to finish ,and save the gcode file to TF card.

### 2. Print

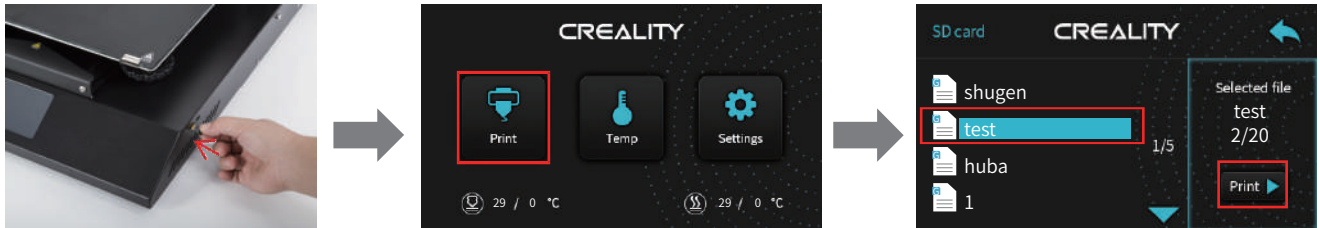

Insert the TF card → Print → Select Model → Print

# 10.Circuit Wiring

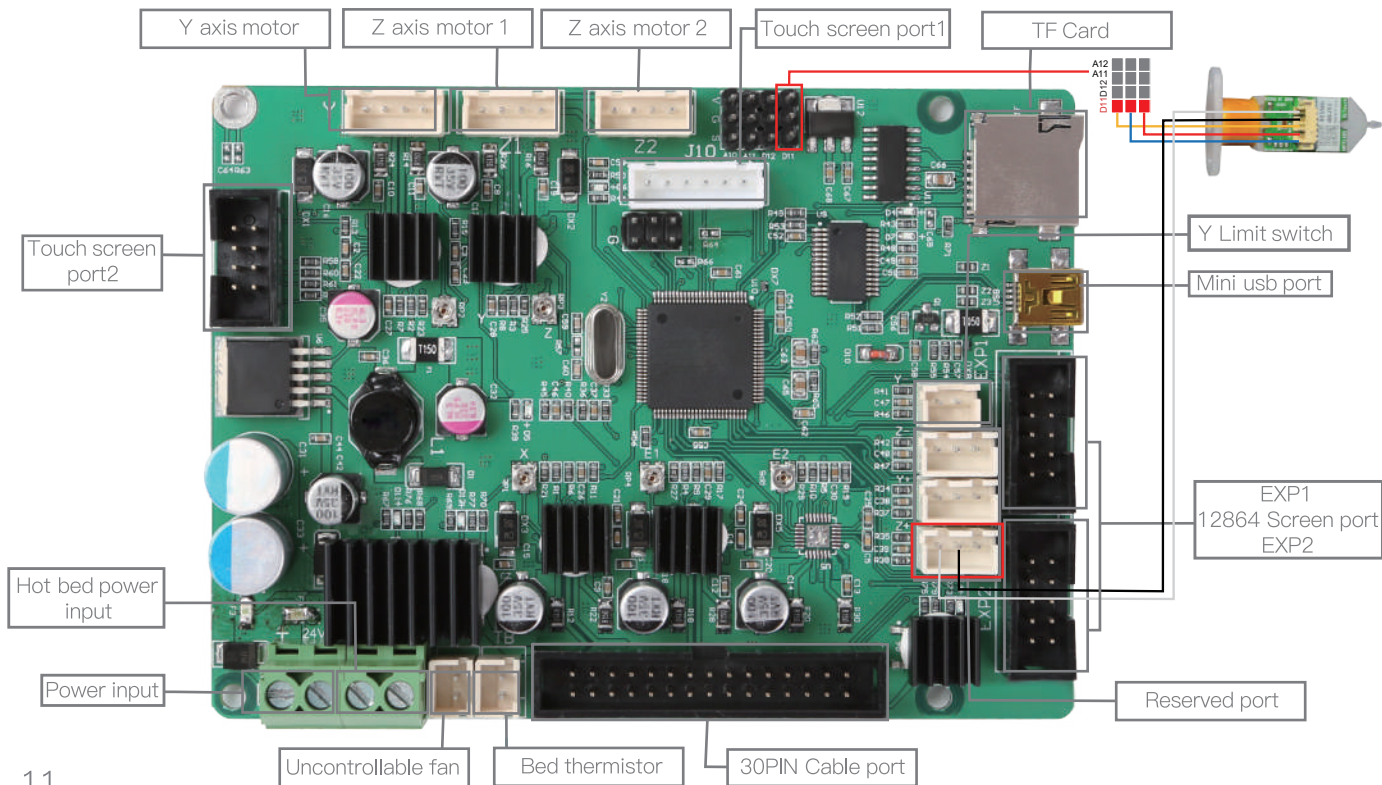

# After– Sales Service

## Service

1, The printer can be returned within seven days, 15 days replacement, one year warranty, lifetime maintenance.

## Replacement Requirement

- 1.The appearance of the product is intact, without damage, scratches, smudges, cracks, deformation, etc.;
2. Machine parts, tools and others are complete;
- 3.Provide a complete and valid purchase invoice and warranty, product number should be the same.

## Warranty Coverage

1. The following accessories are not included in the warranty coverage if they are not damaged by transportation: platform sticker; platform forming plate; acrylic cover; card reader and TF card; platform glass; USB cable; filament; rack and tools,etc.
2. Profile: Before we deliver the goods, we will do the machine test, so maybe there will be light scratch, or due to long–distance transportation, which scratch the profile a little bit. in the premise of not affecting the normal use, in principle, not within the scope of warranty;
3. Nozzle assembly (nozzle, heating block, throat pipe,heat sink, Teflon tube, etc.) warranty period is 3 months, if it is damage after the warranty expires, you need to purchase another one;
4. Motherboard, LCD display, power supply, hot bed,warranty period is 12 months, if there are quality problems, you can get free maintenance; over the warranty period, can be sent back to the original factory maintenance, the users need to bear the return shipping and maintenance costs;
5. Not included in warranty coverage:
  - (1)It is not possible to provide an effective after–sales service card or serial number;
  - (2) The whole machine and components exceed the warranty period;

- (3) Equipment failure or damage caused by unauthorized modification of the equipment (private modification includes: 1. modification of the nozzle assembly; 2. modification of the machine structure; 3. use of third–party components; 4. use of third–party firmware procedures or change the original Factory firmware program, etc.);
- (4) Equipment failure or damage due to incorrect installation and use;
- (5) Equipment failure or damage caused by the use of the equipment in a working environment not specified by the product;
- (6) Equipment failure or damage due improper use (beyond workload, etc.) or maintenance (moisture, etc.);
- (7) Equipment failure or damage due to the use of other branded components or low quality consumables.

## Statement:

For better highlighting the function and effectiveness of 3d printer and promoting the development of global market economic, strengthening the user self–discipline of 3d industry and establishing a good image of 3d printing, since Creality 3d printer have passed all kinds of authorized product certificates and quality management system.hereby we declare that it is strictly forbidden to use our printer to print any products or equipment that are in violation of the specific country and regions legislation.

The revision date: April 9, 2020



SHENZHEN CREALITY 3D TECHNOLOGY CO.,LTD.  
11F & Room 1201,Block 3,JinChengYuan,Tongsheng Community,Dal  
ang,Longhua District,Shenzhen,China,518109  
Official Website: [www.creality.com](http://www.creality.com)  
Tel: +86 755-85234565  
E-mail: [info@creality.com](mailto:info@creality.com) [cs@creality.com](mailto:cs@creality.com)

